

# 390D L

Hydraulic Excavators



## Engine

Engine Model	Cat® C18 ACERT™ (ATAAC)
Net Power – ISO 9249	390 kW (523 hp)
Net Power – SAE J1349	390 kW (523 hp)

## Weights

Operating Weight – Long Undercarriage	90 390 kg
---------------------------------------	-----------

## Drive

Maximum Travel Speed	4.5 km/h
Maximum Drawbar Pull	590 kN

## Features

### Performance

High level of sustained production, improved performance, reliability and durability increase your productivity and lower your operating costs.

### Engine

The Cat® C18 engine uses ACERT™ Technology to meet Stage IIIA emission regulations with exceptional performance capabilities and proven reliability.

### Operator Station

Superior cab comfort and visibility provide an excellent working environment. The full-color monitor with graphic display features enhanced functionality to provide a simple, comprehensive machine interface.

### Maximum Versatility

A variety of work tools, including buckets, are available for applications such as demolition, site clean-up, scrap processing, breaking up road surfaces and bedrock through Cat® Work Tools.

### Service and Maintenance

Fast, easy service has been designed in with long service intervals, advanced filtration, convenient filter access and user-friendly electronic diagnostics for increased productivity and reduced maintenance costs.

## Contents

Hydraulics .....	3
Operator Station.....	4
Engine .....	5
Control System .....	6
Structures.....	7
Undercarriage .....	8
Front Linkage .....	9
SmartBoom™.....	10
Buckets and Teeth .....	11
Work Tools.....	12
Environment.....	13
Service and Maintenance .....	14
Complete Customer Support.....	15
390D L Hydraulic Excavator Specifications.....	16
390D L Standard Equipment .....	32
390D L Optional Equipment.....	33
Notes.....	34



**The Cat® 390D L Hydraulic Excavator has excellent control, high stick and bucket forces, simplified service and a comfortable operator station to increase your productivity and lower operating costs.**

# Hydraulics

Precise power and control to move more material

## Main Pumps

The hydraulic system includes three pumps with an independent swing circuit. The hydraulic circuit utilizes a load-sensing system to ensure high efficiency and productivity with little hydraulic loss.

## Swing Dampening Valve

A swing dampening valve reduces wagging, which produces smoother, time-saving swing stops.

## Implement Pressure

Increased implement pressure provides shorter cycle times, stronger digging forces and greater bucket fill factors.

## Auxiliary Hydraulics

Standard auxiliary hydraulics are managed electronically, making the machine more versatile.

## Proportional Priority Pressure Compensation (PPPC) Hydraulics

The load-sensing PPPC system with proprietary electronic actuation provides excellent efficiency and controllability.

- Pump discharge flow matches the operator's desired speed, which makes for extremely smooth shifting from neutral to full stroke.
- Pump flow volume all goes to the actuator, which ensures the delivery of maximum hydraulic energy. Even if load pressure changes during actuation, the control lever position does not vary, which makes for consistent, reliable operation.



# Operator Station

Simple and comfortable for maximum productivity



## **Cab Design**

The spacious cab provides excellent visibility and ergonomics. The full-color monitor provides the operator with easy-to-read, comprehensive machine information.

## **Cab Exterior**

The cab utilizes thick steel tubing along the bottom to reduce vibration and fatigue. The cab structure allows the FOGS to be bolted directly to the cab either at the factory or as an attachment.

## **Cab Mounts**

The cab shell is attached to the frame with viscous rubber cab mounts, which dampen vibrations and sound levels to enhance operator comfort.

## **Additional Features**

The 390D L operator station has many features for operator comfort.

- Premium air suspension seat with adjustable/tilt console.
- Low effort joysticks.
- Numeric view of fuel consumption on the monitor.
- Optional rearview camera for added safety.
- Optional HID (High Intensity Discharge) lights with time delay for the boom and cab lights.
- Two-way radio-ready option.



# Engine

Power to move more dirt with less fuel

## **Cat® C18 Engine**

The C18 engine with ACERT™ Technology powers the 390D L. The C18 has a proven record of long life. Materials like high-strength steels and cast iron contribute to its durability, while uniquely designed water-cooled turbochargers and mechanically actuated fuel injection contribute to its reliability.

## **Improved Fuel Efficiency**

The 390D L optimizes fuel consumption through flexible power settings incorporated into the ADEM™ controller, which electronically manages engine response to load demand. The operator can select High Production, Standard or Economy mode to meet application requirements.

## **Hydraulic Cooling Fans**

The 390D L uses hydraulically driven cooling fans that operate based on coolant and hydraulic oil temperatures. To reduce load when cranking the engine, the cooling fan speed is fixed for a set amount of time after the engine is started and then is increased gradually to a specific speed.

## **Reversible Fan**

A reversible fan option is offered to help clean the cooling package for increased uptime and reduced service cost.

# Control System

Easy to view, easy to manage



## Monitor Display

The monitor is a full-color Liquid Crystal Display (LCD). A master caution lamp blinks ON and OFF when one of the critical conditions below occurs:

- Engine oil pressure low
- Coolant temperature high
- Hydraulic oil temperature high

Under normal conditions or the default condition, the monitor display screen is divided into four areas: clock and throttle dial, gauge, event display and multi-functional display.

## Gauge Display

Three analog gauges – fuel level, hydraulic oil temperature and coolant temperature – are displayed in this area.

## Pattern Control Changer

The standard hand control pattern changer can be accessed through the monitor to utilize either the standard excavator control pattern or backhoe pattern, making it easier for operators to work in the mode they are accustomed.

## Electronic Joysticks

Electronic joysticks provide features not possible with hydraulic pilot valves:

- Eliminate pilot lines in cab for quieter operation
- Simple pattern change through the monitor

## Operator Gain/Response

This is used to suit the operator preference or application.

- Faster for quick response
- Slower for more precision

## Product Link

Product Link is a proprietary Caterpillar technology that tracks machine location, product health, hours of use and fuel consumption. This information is transmitted back to customers to help maximize machine productivity.

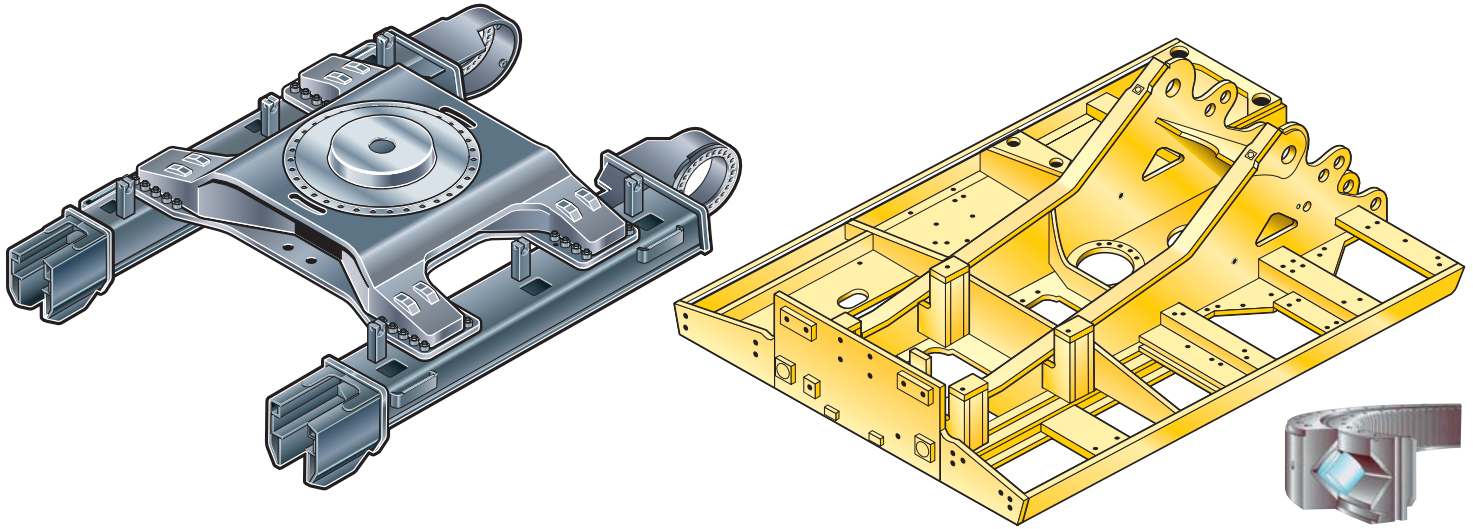

# Structures

Rugged and durable for many applications

## Variable Gauge Undercarriage

The long variable gauge undercarriage is standard, providing a wide, stable base for operating or a narrow gauge for reduced shipping width. Changes to the 390D L undercarriage include:

- Improved track link to reduce and avoid stresses
- Improved carrier rollers to reduce the risk of leaking lubrication oil
- Improved forged idler for added durability in severe underfoot conditions
- Positive Pin Retention 2 (PPR2) to prevent pin movement

## Catwalks

Slip-resistant catwalks are 500 mm wide and stretch the length of the machine to provide safe access to major service points.

## Track Roller Frame

The thick, steel-plated track roller frame is welded into a box structure, which provides increased rigidity and impact resistance.

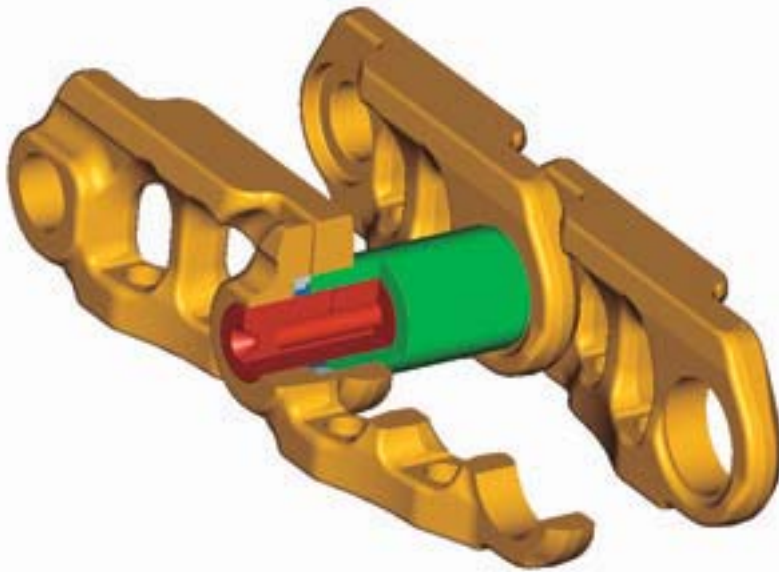

# Undercarriage

Strong, stable and durable

## **Undercarriage**

The undercarriage supports the swing bearing and upper structure and is the link that transmits the reaction forces from digging to the ground. The strength of the Cat undercarriage plays a major factor in machine stability and durability.

## **Track Roller Frame**

The track roller frame has been improved by installing a longer stroke recoil spring and lowering the front idler. The longer recoil spring improves durability and service life of the undercarriage, and the offset idler increases the stability of the machine while working over the front.

## **Positive Pin Retention 2 (PPR2)**

Track links with the PPR2 are provided as standard on the 390D L. The PPR2 is designed to prevent looseness of the track pin in the track link and to reduce stress concentrations. The PPR2 system eliminates pin movement for increased service life.

## **Carrier Rollers**

The carrier rollers use a floating Duo-Cone seal, which reduces the risk of leaking lubricating oil.

## **Forged Idler**

The durable forged idler is standard on the 390D L.

# Front Linkage

Built to perform the toughest tasks

## Front Linkage

Cat® Excavator booms and sticks are built for performance and long service life.

- Casting and forgings are used at high stress areas such as the boom nose, boom foot, boom cylinder and stick foot.
- All booms and sticks are stress-relieved for optimal life and durability while minimizing weight for improved performance.
- All booms and sticks are ultrasonic inspected to ensure reliability.

## Bucket Linkage

Two bucket linkages are available for the 390D L. Both are available with or without a lifting eye.

## Boom Construction

390D L booms feature a large cross section to improve strength, reduce weight and maximize payload. Baffle plates reinforce the boom interior for higher rigidity.

## Stick Construction

Sticks are made of high-tensile strength steel in a box-section design, making them strong and light. All sticks are reinforced with a thick baffle plate for added rigidity. The connection between stick and boom is made of forged steel, and a thick steel plate is used at the bucket connecting location for increased strength and rigidity at load-bearing points. An additional wear plate is added to the bottom plate to protect against damage. There are two reach sticks, three general purpose sticks and two mass sticks available to meet your needs.

## Linkage Pins

All front linkage pins have thick chrome plating, giving them high wear resistance. Each pin diameter is made to distribute the shear and bending loads associated with the stick and to help ensure long pin, boom and stick life.

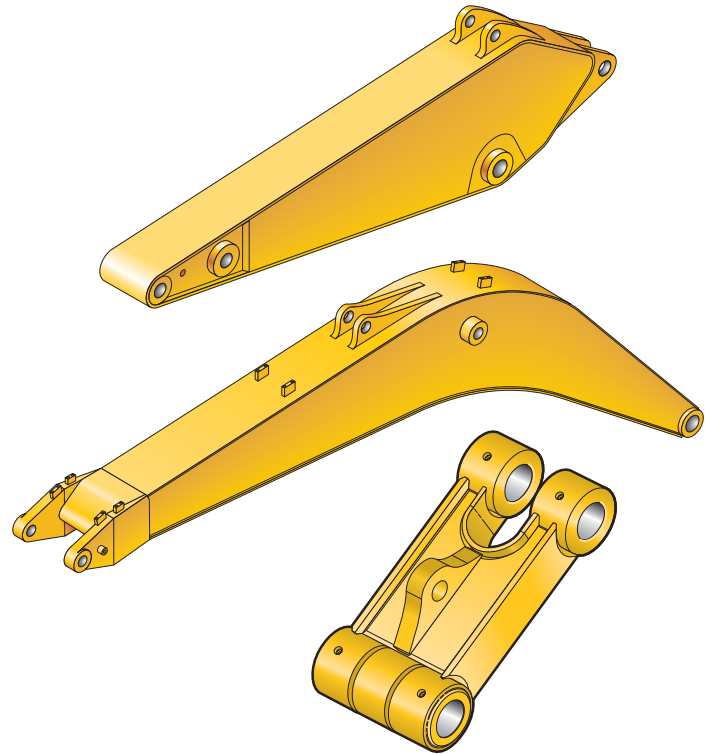

# SmartBoom™

Reduces stress and vibrations transmitted to the machine

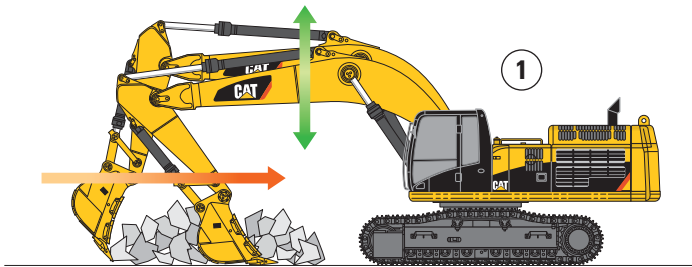

## Rock Scraping (1)

Scraping rock and finishing work is easy and fast. SmartBoom™ simplifies the task and allows the operator to fully concentrate on the stick and bucket while the boom freely goes up and down without using pump flow.

## Hammer Work (2)

It has never been this productive and operator-friendly. The front parts automatically follow the hammer while penetrating the rock. Blank shots or excessive force on the hammer are avoided, resulting in longer life for the hammer and machine. Similar advantages are applicable when using vibratory plates.

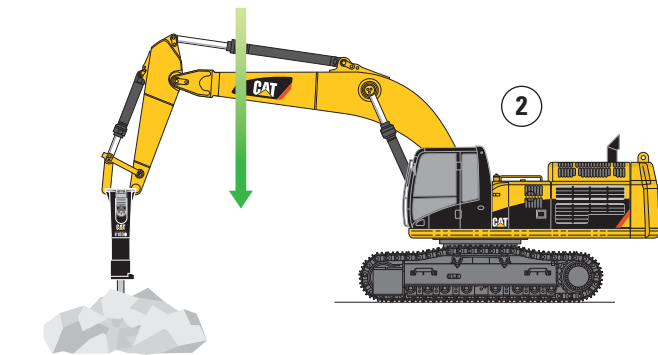

## Truck Loading (3)

Loading trucks from a bench is more productive and fuel efficient as the return cycle is reduced while the boom down function does not require pump flow.

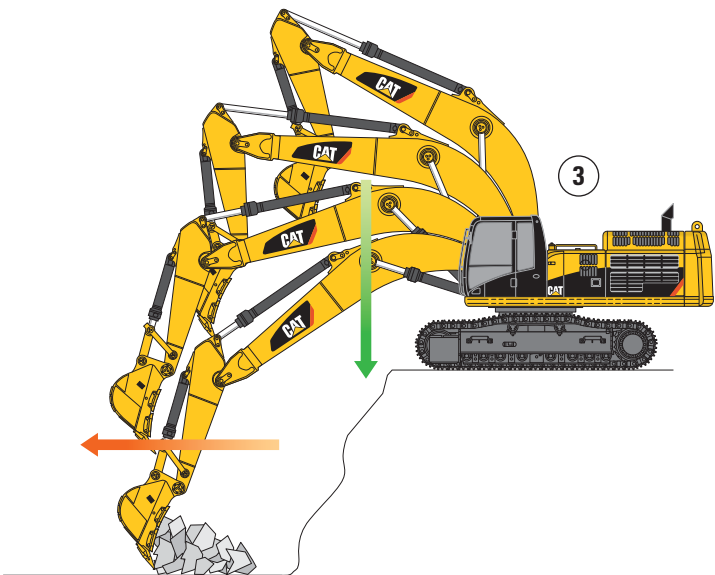

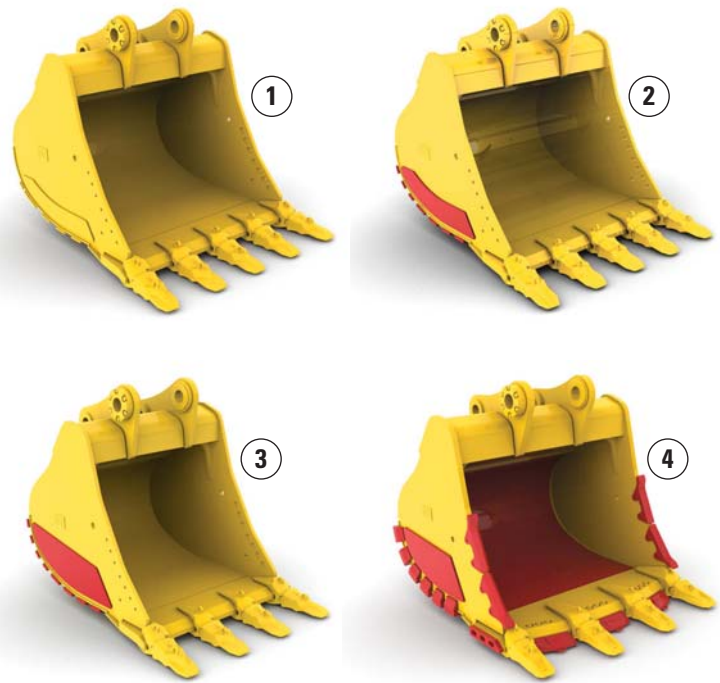

# Buckets and Teeth

Designed and built for rugged work

## Optimized Package

Caterpillar offers a wide range of buckets – each designed and field tested to function as an integral part of your excavator. All Cat® Buckets feature K Series™ Ground Engaging Tools (GET). Buckets are available in four levels of durability and are built to take full advantage of the machine's power.

## General Duty (GD)

General Duty buckets are designed for use in low impact, low abrasion material such as dirt, loam and mixed compositions of dirt and fine gravel.

## Heavy Duty (HD)

Heavy Duty buckets are the most popular and a good “centerline” choice. This bucket style is a good starting point when application conditions are not known. Heavy Duty buckets are designed for a wide range of impact and abrasion conditions, including mixed dirt, clay and rock.

## Severe Duty (SD)

Severe Duty buckets are designed for higher abrasion conditions such as shot granite. When compared to the Heavy Duty bucket, wear bars and wear plates are substantially thicker and larger for added protection.

## Extreme Duty (XD)

Extreme Duty buckets are designed for very high abrasion conditions such as granite quarries. Corner shrouds have been added, and side wear plates are larger for added protection.

1) Severe Duty 2) Heavy Duty 3) General Duty 4) Extreme Duty

# Work Tools

Solutions for many applications



## **Increase Machine Versatility**

The Cat combination of machine and tool provides a total solution for just about any application. Work tools can be mounted either directly to the machine or to a quick coupler, making it fast and easy to release one work tool and pick up another.

## **Quick Coupler**

Cat quick couplers enable the operator to simply release one work tool and pick up another so your hydraulic excavator becomes extremely versatile.

## **Work Tools**

An extensive range of Cat Work Tools for the 390D L includes buckets, grapples, shears, multi-processors and rippers. Each is designed to optimize the versatility and performance of your machine. Cat Work Tools and couplers are ready to work in a variety of applications, such as site and structure demolition, debris clean-up, truck loading, scrap processing and breaking road surfaces and bedrock.

## **Hydraulic Kits**

Caterpillar offers field-installed hydraulic kits designed to simplify the process of ordering and installing the right kit. Modular kit designs integrate Cat Work Tools with Cat Hydraulic Excavators. Every kit is easy to install. Hoses are pre-made, tubes are pre-bent and pre-painted and there are comprehensive instructions.



# Environment

Built to meet a range of requirements

## Emissions

ACERT™ Technology is a differentiated technology that reduces emissions at the point of combustion. It capitalizes on proven Caterpillar leadership in three core engine systems: fuel, air and electronics.

## Electro Magnetic Compliance

The 390D L meets the following EMC (Electro Magnetic Compliance) requirements:

- ISO 13766 Earth Moving Machinery – Electromagnetic compliance
- EU Directive 89/336/EEC
- Aus EMC Framework

## Fluid Management

Many serviceability elements are designed into the 390D L to limit fluid spillage while performing routing maintenance.

## Filters

Hydraulic return filters are vertically mounted, capsule-type with shutoffs in the inlet and outlet ports.

## Ecology Drains

Ecology drains for the fuel and hydraulic tanks allow fluids to be captured in a container when draining the tanks.

## Certified Rebuild

When most other manufacturers' models require replacement, Cat equipment can be rebuilt using many remanufactured parts. This means less materials going to landfills.

# Service and Maintenance

Fast, easy and safe access is built in



## **Service Intervals**

Long service intervals reduce maintenance costs. Engine oil, oil filter and fuel filters are rated at 500 hours.

## **Oil Sample and Pressure Ports**

Oil sample and pressure ports provide easy checking of machine condition and are standard on every machine.

## **Hydraulic Capsule Filters**

The return filters, or capsule filters, for the hydraulic system are located beside the hydraulic tank. The filter elements are removable without spilling hydraulic oil.

## **Service Points**

Service points are centrally located with easy access to facilitate routine maintenance.

## **Pilot Hydraulic System Filter**

A pilot hydraulic system filter keeps contaminants from the pilot system and is located in the pump compartment.

## **Remote Greasing Block**

A concentrated remote greasing block on the boom delivers grease to hard-to-reach locations.

## **Radial Seal Cleaner**

The radial seal main air cleaner with precleaners has a double-layered filter element for more efficient filtration. No tools are required to change the element.

## **Fuel-Water Separator**

The fuel-water separator removes water from fuel, even when under pressure, and the water level can be monitored in the cab.



# Complete Customer Support

Cat<sup>®</sup> dealer services to help you operate longer with lower costs

## **Product Support**

Cat dealers utilize a worldwide parts network to minimize machine downtime. Plus you can save money with Cat remanufactured components.

## **Machine Selection**

Make detailed comparisons of machines you are considering. What are the job requirements and machine attachments? What production is needed? Your Cat dealer can provide recommendations.

## **Purchase**

Consider financing options and day-to-day operating costs. Look at dealer services that can be included in the machine's cost to yield lower owning and operating costs over time.

## **Customer Support Agreements**

Cat dealers offer a variety of customer support agreements and work with you to develop a plan to meet specific needs. These plans can cover the entire machine, including attachments, to help protect your investment.

## **Operation**

Improving operating techniques can boost your profits. Your Cat dealer has videos, literature and other ideas to help you increase productivity. Caterpillar also offers simulators and certified operator training to help maximize the return on your investment.

## **Replacement**

Repair, rebuild or replace? Your Cat dealer can help you evaluate the cost involved so you can make the right choice.

# 390D L Hydraulic Excavator Specifications

## Engine

Engine Model	Cat® C18 ACERT™ (ATAAC)
Net Power – ISO 9249	390 kW (523 hp)
Net Power – SAE J1349	390 kW (523 hp)
Net Power – EEC 80/1269	390 kW (523 hp)
Bore	145 mm
Stroke	183 mm
Displacement	18.1 L

- The 390D L meets Stage IIIA emission requirements.
- No engine power derating required below 2300 m altitude.
- Net power advertised is the power available at the flywheel when the engine is equipped with fan, air cleaner, muffler and alternator.

## Weights

Operating Weight – Long Undercarriage	90 390 kg
---------------------------------------	-----------

- 7.25 m Mass Boom, M3.4 m Stick, 4.6 m<sup>3</sup> HD Bucket and 650 mm shoes.

## Track

Number of Shoes Each Side – Long Undercarriage	51
Number of Track Rollers Each Side – Long Undercarriage	9
Number of Carrier Rollers Each Side	3

## Swing Mechanism

Swing Speed	5.9 rpm
Swing Torque	260 kN·m

## Drive

Maximum Travel Speed	4.5 km/h
Maximum Drawbar Pull	590 kN

## Hydraulic System

Main System – Maximum Flow (Total)	980 L/min
Swing System – Maximum Flow	450 L/min
Maximum Pressure – Equipment – Normal	350 bar
Maximum Pressure – Equipment – Heavy Lift	350 bar
Maximum Pressure – Travel	350 bar
Maximum Pressure – Swing	260 bar
Pilot System – Maximum Flow	90 L/min
Pilot System – Maximum Pressure	41.2 bar
Boom Cylinder – Bore	210 mm
Boom Cylinder – Stroke	2262 mm
HB2 Family Bucket Cylinder – Bore	200 mm
HB2 Family Bucket Cylinder – Stroke	1451 mm
JC Family Bucket Cylinder – Bore	220 mm
JC Family Bucket Cylinder – Stroke	1586 mm

## Service Refill Capacities

Fuel Tank Capacity	1240 L
Cooling System	101 L
Engine Oil	65 L
Swing Drive (each)	19 L
Final Drive (each)	21 L
Hydraulic System (including tank)	995 L

## Sound Performance

Performance	ANSI/SAE J1166 OCT98
-------------	----------------------

- Operator Sound – The operator sound level measured according to the procedures specified in ISO 6394:1998 is 85 dB(A), for cab offered by Caterpillar, when properly installed and maintained and tested with doors and windows closed.
- Exterior Sound – The labeled spectator sound power level measured according to the test procedures and conditions specified in 2000/14/EC is 108 dB(A).
- Hearing protection may be needed when operating with an open operator station and cab (when not properly maintained or doors/windows open) for extended periods or in a noisy environment.

## Standards

Brakes	SAE J1026 APR90
Cab/FOGS	SAE J1356 FEB88 / ISO 10262

- ISO 10262 OPS, front and top
- ISO J1356 FOGS, front and top

## Dimensions

All dimensions are approximate

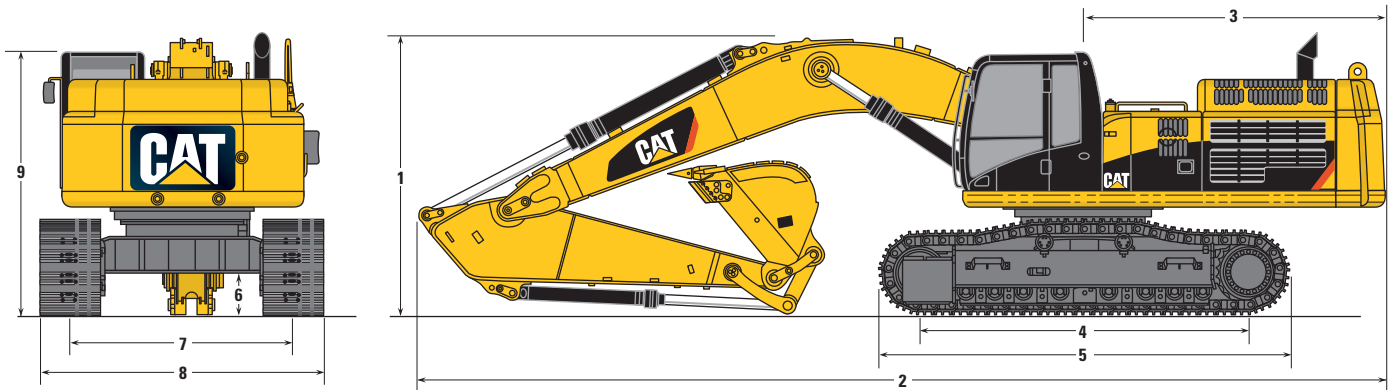

Stick		Reach Boom 10.0 m			General Purpose Boom 8.4 m			Mass Boom 7.25 m			
		R5.5 m	R4.4 m	R5.5 m	R4.4 m	GP3.7 m	GP3.4 m	GP2.92 m	M3.4 m	M2.92 m	
Bucket		HB3.9 m <sup>3</sup>	HB3.9 m <sup>3</sup>	HB4.6 m <sup>3</sup>	HB4.6 m <sup>3</sup>	HB4.6 m <sup>3</sup>	JC4.6 m <sup>3</sup>	JC4.6 m <sup>3</sup>	JC6.0 m <sup>3</sup>	JC6.0 m <sup>3</sup>	
1	Shipping Height	mm	5430	5030	5840	5290	5010	5160	4970	5310	4900
2	Shipping Length	mm	16 280	16 320	14 490	14 700	14 710	14 720	14 910	13 560	13 690
3	Tail Swing Radius	mm	4680	4680	4680	4680	4680	4680	4680	4680	4680
4	Length to Center of Rollers***	mm	5120	5120	5120	5120	5120	5120	5120	5120	5120
5	Track Length****	mm	6360	6360	6360	6360	6360	6360	6360	6360	6360
6	Ground Clearance	mm	900	900	900	900	900	900	900	900	900
7	Track Gauge (Shipping)*	mm	2750	2750	2750	2750	2750	2750	2750	2750	2750
8	Transport Width**	mm	4260 (LC)	4260 (LC)	4260 (LC)	4260 (LC)	4260 (LC)	4260 (LC)	4260 (LC)	4260 (LC)	4260 (LC)
9	Cab Height	mm	3760	3760	3760	3760	3760	3760	3760	3760	3760

\* Track gauge in extended (working) position: 3510 mm.

\*\* Transport width shown for 750 mm.

Add 150 mm for 900 mm shoes.

Subtract 100 mm for 650 mm shoes.

\*\*\* STD 4600 mm (STD), 5120 mm (LC).

\*\*\*\* STD 5840 mm (STD), 6360 mm (LC).

# 390D L Hydraulic Excavator Specifications

## Working Ranges

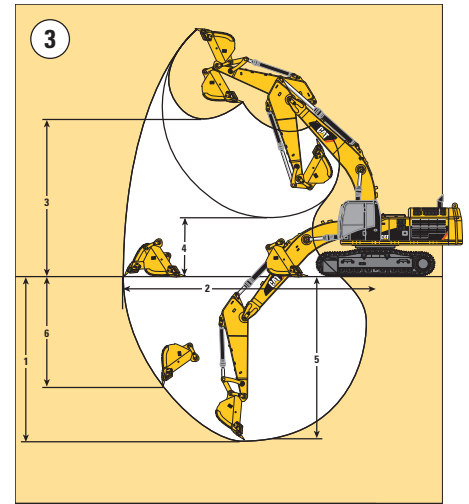
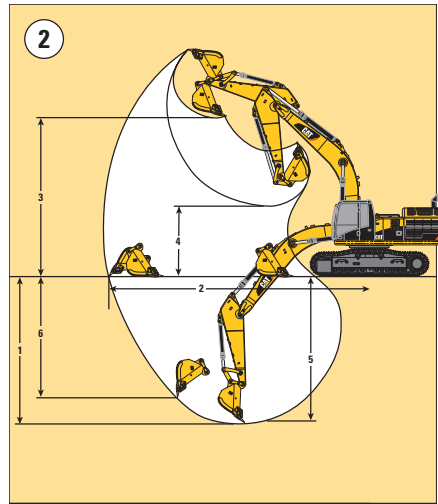
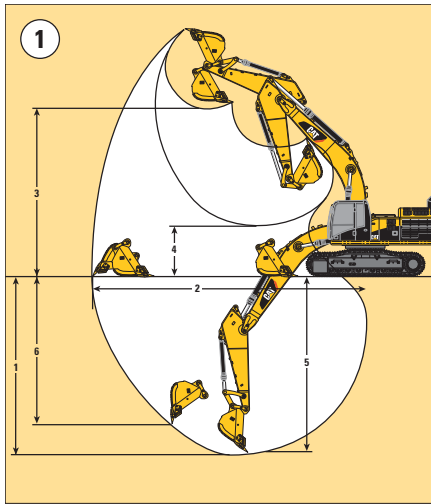

①

**Reach Boom  
10.0 m**

②

**General Purpose Boom  
8.4 m**

③

**Mass Boom  
7.25 m**

		① Reach Boom 10.0 m		② General Purpose Boom 8.4 m				③ Mass Boom 7.25 m		
Stick		R5.5 m	R4.4 m	R5.5 m	R4.4 m	GP3.7 m	GP3.4 m	GP2.92 m	M3.4 m	M2.92 m
Bucket		HB3.9 m <sup>3</sup>	HB3.9 m <sup>3</sup>	HB4.6 m <sup>3</sup>	HB4.6 m <sup>3</sup>	HB4.6 m <sup>3</sup>	JC4.6 m <sup>3</sup>	JC4.6 m <sup>3</sup>	JC6.0 m <sup>3</sup>	JC6.0 m <sup>3</sup>
<b>1</b> Maximum Digging Depth	mm	11 810	10 710	10 760	9660	8960	8690	8220	7650	7170
<b>2</b> Maximum Reach at Ground Line	mm	17 250	16 230	15 730	14 690	14 040	13 910	13 480	12 690	12 240
<b>3</b> Maximum Loading Height	mm	10 950	10 520	9720	9270	8980	9090	8910	8200	7980
<b>4</b> Minimum Loading Height	mm	3310	4410	1940	3040	3740	4020	4480	3200	3670
<b>5</b> Maximum Depth Cut for 2240 mm Level Bottom	mm	11 710	10 600	10 660	9550	8840	8560	8080	7520	7030
<b>6</b> Maximum Vertical Wall Digging Depth	mm	8390	7380	7860	6850	5940	6190	5950	5100	4700
Bucket Digging Force										
(SAE)	kN	322	321	322	321	321	412	411	404	404
(ISO)	kN	365	363	365	363	363	471	470	471	470
Stick Digging Force										
(SAE)	kN	230	268	230	268	300	315	337	314	342
(ISO)	kN	236	276	236	276	310	325	350	325	356

## Operating Weight\* and Ground Pressure

	Track					
	900 mm Shoes		750 mm Shoes		650 mm Shoes	
	kg	bar	kg	bar	kg	bar
Reach Boom – 10.0 m						
Bucket – 3.9 m <sup>3</sup>						
R5.5 m	90 070	0.88	88 950	1.0	88 080	1.2
R4.4 m	89 570	0.88	88 450	1.0	87 580	1.1
General Purpose Boom – 8.4 m						
Bucket – 4.6 m <sup>3</sup>						
R5.5 m	88 690	0.87	87 570	1.0	86 690	1.2
R4.4 m	88 180	0.86	87 070	1.0	86 190	1.2
GP3.4 m	91 050	0.89	89 930	1.0	89 060	1.2
GP2.92 m	90 680	0.89	89 570	1.0	88 690	1.2
Mass Boom – 7.25 m						
Bucket – 6.0 m <sup>3</sup>						
M3.4 m	92 380	0.90	91 260	1.0	90 390	1.2
M2.92 m	92 130	0.90	91 010	1.0	90 140	1.2

\* Operating weight includes full fuel tank and 75 kg operator.

## Major Component Weights

	kg
Base machine with counterweight and 750 mm shoes (without front linkage)	67 950
Two boom cylinders	1720
Boom (includes lines, pins, stick cylinder)	
Reach Boom – 10.0 m	9750
General Purpose Boom – 8.4 m	8310
Mass Boom – 7.25 m	8480
Stick (includes lines, pins, bucket cylinder and linkage)	
R5.5 m	5430
R4.4 m	4930
GP3.4 m	5270
GP2.92 m	4910
M3.4 m	5420
M2.92 m	5170

# 390D L Hydraulic Excavator Specifications

## 390D L Bucket Specifications and Compatibility – EAME

	Linkage	Width	Capacity	Weight	Fill	Reach Boom		General Purpose Boom					ME Boom	
		mm	m <sup>3</sup>	kg	%	R4.4HB2	R5.5HB2	R4.4HB2	R5.5HB2	G3.7HB2	G2.9JC	G3.4JC	M2.9JC	M3.4JC
<b>Without Quick Coupler</b>														
General Duty (GD)	HB2	1350	3.0	3406	100%	○	⊗	●	●	●	–	–	–	–
	HB2	1650	3.9	3794	100%	⊗	⊗	⊙	○	●	–	–	–	–
	HB2	1900	4.6	4155	100%	⊗	⊗	○	⊗	●	–	–	–	–
	HB2	1100	2.2	2856	100%	●	⊙	●	●	●	–	–	–	–
	HB2	1350	2.9	3187	100%	⊙	⊗	●	●	●	–	–	–	–
	HB2	1650	3.7	3650	100%	⊗	⊗	●	○	●	–	–	–	–
	HB2	1900	4.3	3923	100%	⊗	⊗	⊙	○	●	–	–	–	–
	HB2	2000	4.6	4032	100%	⊗	⊗	○	⊗	●	–	–	–	–
	JC	2300	5.7	5822	100%	–	–	–	–	–	○	⊗	●	⊙
	JC	2420	6.0	6004	100%	–	–	–	–	–	⊗	⊗	⊙	⊙
JC	2575	6.5	6238	100%	–	–	–	–	–	⊗	⊗	⊙	○	
General Duty XL (GDXL)	HB2	2000	5.3	4400	100%	⊗	⊗	⊗	⊗	⊙	–	–	–	–
	HB2	2250	6.0	4796	100%	⊗	⊗	⊗	⊗	○	–	–	–	–
Heavy Duty (HD)	JC	1750	4.1	4799	100%	–	–	–	–	–	●	⊙	●	●
	JC	2090	5.1	5441	100%	–	–	–	–	–	○	○	●	●
	JC	2300	5.7	5892	100%	–	–	–	–	–	○	⊗	●	⊙
Severe Duty (SD)	HB2	1100	2.3	3282	90%	●	⊙	●	●	●	–	–	–	–
	HB2	1350	3.0	3736	90%	○	⊗	●	●	●	–	–	–	–
	HB2	1650	3.9	4163	90%	⊗	⊗	●	○	●	–	–	–	–
	HB2	1900	4.6	4553	90%	⊗	⊗	○	⊗	●	–	–	–	–
	JC	1960	4.6	6229	90%	–	–	–	–	–	⊙	○	●	●
	JC	2240	5.4	6809	90%	–	–	–	–	–	○	⊗	●	⊙
	JC	2350	5.7	7015	90%	–	–	–	–	–	⊗	⊗	●	⊙
	JC	2440	6.0	7342	90%	–	–	–	–	–	⊗	⊗	⊙	○
Extreme Duty (XD)	JC	2090	5.0	6557	90%	–	–	–	–	–	○	⊗	●	●
	JC	2240	5.4	7733	90%	–	–	–	–	–	⊗	⊗	⊙	○
	JC	2350	5.7	7968	90%	–	–	–	–	–	⊗	⊗	⊙	○
Maximum dynamic load pin-on (payload + bucket)					kg	7535	6350	10 420	8850	12 530	12 420	11 430	15 850	14 600
<b>With Quick Coupler (CW-70)</b>														
Severe Duty (SD)	JC	2240	5.4	6559	90%	–	–	–	–	–	⊗	⊗	⊙	○
	JC	2350	5.7	6765	90%	–	–	–	–	–	⊗	⊗	⊙	○
Maximum dynamic load with CW coupler (payload + bucket)					kg	6115	4930	9000	7430	11 110	11 000	10 010	14 430	13 180

The above figures are based on maximum recommended dynamic working weights with front linkage fully extended at ground line with bucket curled. They do not exceed a stability ratio of 1.25.

Capacity based on ISO 7451.

Bucket weights include HD Long tips.

- 1800 kg/m<sup>3</sup> or greater
- ⊙ 1500 kg/m<sup>3</sup> or less
- 1200 kg/m<sup>3</sup> or less
- ⊗ Not Recommended

## 390D L Reach Boom Lift Capacities – EAME



Load Point Height



Load at Maximum Reach



Load Radius Over Front



Load Radius Over Side

**Boom – 10.0 m**

**Coupler – N/A**

**Bucket – None**

**Stick – R5.5 m**

**Shoes – 750 mm double grouser**

Load Point Height	kg	3.0 m		4.5 m		6.0 m		7.5 m		9.0 m		10.5 m		12.0 m		13.5 m		15.0 m		m			
		Front	Side	Front	Side	Front	Side	Front	Side	Front	Side	Front	Side	Front	Side	Front	Side	Front	Side	Front	Side		
12.0 m	kg																			*9750	*9750	11.82	
10.5 m	kg												*12 200	*12 200							*9400	*9400	12.87
9.0 m	kg											*13 700	*13 700	*12 900	12 350	*10 150	9800				*9250	*9250	13.67
7.5 m	kg											*14 400	*14 400	*13 300	12 050	*12 500	9700				*9250	8650	14.27
6.0 m	kg							*20 250	*20 250	*17 250	*17 250	*15 250	14 500	*13 850	11 650	*12 800	9450				*9400	8000	14.69
4.5 m	kg					*29 300	*29 300	*22 600	*22 600	*18 750	17 500	*16 200	13 850	*14 450	11 200	*13 150	9150				*9650	7600	14.94
3.0 m	kg					*20 200	*20 200	*24 700	21 250	*20 100	16 450	*17 100	13 150	*15 000	10 700	*13 450	8850	*10 400	7350		*10 050	7300	15.04
1.5 m	kg					*15 750	*15 750	*26 100	20 000	*21 150	15 600	*17 850	12 550	*15 500	10 300	13 200	8600				*10 600	7200	14.99
Ground Line	kg					*17 000	*17 000	*26 700	19 200	*21 700	14 950	*18 250	12 050	15 400	9950	12 950	8350				11 300	7250	14.78
-1.5 m	kg			*11 350	*11 350	*20 750	*20 750	*26 550	18 800	*21 800	14 550	*18 350	11 750	15 150	9700	12 800	8200				11 650	7450	14.42
-3.0 m	kg	*12 300	*12 300	*16 800	*16 800	*26 150	26 150	*25 700	18 650	*21 300	14 350	*17 950	11 550	15 000	9600	12 750	8150				12 300	7850	13.88
-4.5 m	kg	*17 900	*17 900	*23 000	*23 000	*29 200	26 350	*24 150	18 700	*20 200	14 350	*17 050	11 550	*14 350	9600						*12 300	8550	13.14
-6.0 m	kg	*24 100	*24 100	*30 400	*30 400	*26 050	*26 050	*21 850	18 950	*18 350	14 500	*15 350	11 700	*12 400	9800						*12 000	9650	12.18
-7.5 m	kg			*25 300	*25 300	*21 700	*21 700	*18 450	*18 450	*15 400	14 900	*12 350	12 100								*11 350	*11 350	10.91
-9.0 m	kg					*15 650	*15 650	*13 300	*13 300	*10 400	*10 400										*9800	*9800	9.24

\*Indicates that the load is limited by hydraulic lifting capacity rather than tipping load. The above loads are in compliance with hydraulic excavator lift capacity standard ISO 10567:2007. They do not exceed 87% of hydraulic lifting capacity or 75% of tipping load. Weight of all lifting accessories must be deducted from the above lifting capacities. Lifting capacities are based on the machine standing on a firm, uniform supporting surface.

Always refer to the appropriate Operation and Maintenance Manual for specific product information.

# 390D L Hydraulic Excavator Specifications

## 390D L Reach Boom Lift Capacities – EAME



Load Point Height



Load at Maximum Reach



Load Radius Over Front



Load Radius Over Side

**Boom – 10.0 m**

**Coupler – N/A**

**Bucket – None**

**Stick – R5.5 m**

**Shoes – 650 mm double grouser**

Load Point Height	kg	3.0 m		4.5 m		6.0 m		7.5 m		9.0 m		10.5 m		12.0 m		13.5 m		15.0 m		m			
		Front	Side	Front	Side	Front	Side	Front	Side	Front	Side	Front	Side	Front	Side	Front	Side	Front	Side	Front	Side		
12.0 m	kg																			*9750	*9750	11.82	
10.5 m	kg													*12 200	*12 200						*9400	*9400	12.87
9.0 m	kg											*13 700	*13 700	*12 900	12 200	*10 150	9700				*9250	*9250	13.67
7.5 m	kg											*14 400	*14 400	*13 300	11 900	*12 500	9600				*9250	8550	14.27
6.0 m	kg							*20 250	*20 250	*17 250	*17 250	*15 250	14 400	*13 850	11 500	*12 800	9350				*9400	7900	14.69
4.5 m	kg					*29 300	*29 300	*22 600	*22 600	*18 750	17 300	*16 200	13 700	*14 450	11 050	*13 150	9050				*9650	7500	14.94
3.0 m	kg					*20 200	*20 200	*24 700	21 050	*20 100	16 300	*17 100	13 000	*15 000	10 600	13 350	8750	*10 400	7250		*10 050	7250	15.04
1.5 m	kg					*15 750	*15 750	*26 100	19 800	*21 150	15 400	*17 850	12 400	*15 500	10 200	13 050	8450				*10 600	7100	14.99
Ground Line	kg					*17 000	*17 000	*26 700	19 000	*21 700	14 800	*18 250	11 950	15 250	9850	12 800	8250				11 200	7150	14.78
-1.5 m	kg			*11 350	*11 350	*20 750	*20 750	*26 550	18 550	*21 800	14 400	18 150	11 600	15 000	9600	12 650	8100				11 500	7350	14.42
-3.0 m	kg	*12 300	*12 300	*16 800	*16 800	*26 150	25 850	*25 700	18 400	*21 300	14 200	*17 950	11 400	14 850	9450	12 600	8050				12 150	7750	13.88
-4.5 m	kg	*17 900	*17 900	*23 000	*23 000	*29 200	26 050	*24 150	18 450	*20 200	14 150	*17 050	11 400	*14 350	9500						*12 300	8450	13.14
-6.0 m	kg	*24 100	*24 100	*30 400	*30 400	*26 050	*26 050	*21 850	18 700	*18 350	14 350	*15 350	11 550	*12 400	9700						*12 000	9550	12.18
-7.5 m	kg			*25 300	*25 300	*21 700	*21 700	*18 450	*18 450	*15 400	14 700	*12 350	11 950								*11 350	*11 350	10.91
-9.0 m	kg					*15 650	*15 650	*13 300	*13 300	*10 400	*10 400										*9800	*9800	9.24

\*Indicates that the load is limited by hydraulic lifting capacity rather than tipping load. The above loads are in compliance with hydraulic excavator lift capacity standard ISO 10567:2007. They do not exceed 87% of hydraulic lifting capacity or 75% of tipping load. Weight of all lifting accessories must be deducted from the above lifting capacities. Lifting capacities are based on the machine standing on a firm, uniform supporting surface.

Always refer to the appropriate Operation and Maintenance Manual for specific product information.

## 390D L Reach Boom Lift Capacities – EAME



Load Point Height



Load at Maximum Reach



Load Radius Over Front



Load Radius Over Side

**Boom – 10.0 m**

**Coupler – N/A**

**Bucket – None**

**Stick – R4.4 m**

**Shoes – 750 mm double grouser**

Load Point Height	kg	3.0 m		4.5 m		6.0 m		7.5 m		9.0 m		10.5 m		12.0 m		13.5 m		m		
		Front	Side	Front	Side	Front	Side	Front	Side	Front	Side	Front	Side	Front	Side	Front	Side	Front	Side	
12.0 m	kg											*12 950	*12 950					*12 950	*12 950	10.50
10.5 m	kg											*14 550	*14 550					*12 450	*12 450	11.67
9.0 m	kg											*14 850	*14 850	*13 950	11 850			*12 250	10 800	12.55
7.5 m	kg								*17 250	*17 250	*15 450	14 600	*14 150	11 600				*12 250	9650	13.20
6.0 m	kg					*28 250	*28 250	*22 100	*22 100	*18 500	17 800	*16 200	14 000	*14 600	11 250	*13 450	9100	*12 450	8900	13.66
4.5 m	kg							*24 250	21 700	*19 850	16 750	*17 000	13 350	*15 050	10 850	13 500	8900	*12 800	8400	13.93
3.0 m	kg							*25 900	20 250	*20 950	15 850	*17 750	12 750	*15 500	10 450	13 250	8650	12 450	8100	14.04
1.5 m	kg							*26 700	19 350	*21 650	15 150	*18 250	12 250	15 550	10 100	13 050	8450	12 350	7950	13.98
Ground Line	kg					*13 200	*13 200	*26 650	18 850	*21 850	14 650	*18 400	11 850	15 250	9800	12 900	8300	12 550	8050	13.76
-1.5 m	kg					*20 100	*20 100	*25 850	18 650	*21 500	14 400	*18 150	11 650	15 100	9650			13 000	8350	13.36
-3.0 m	kg			*17 950	*17 950	*28 350	26 450	*24 450	18 700	*20 600	14 350	*17 400	11 600	*14 700	9650			*13 200	8900	12.78
-4.5 m	kg			*26 800	*26 800	*26 100	*26 100	*22 350	18 900	*18 950	14 500	*15 950	11 700					*12 950	9850	11.98
-6.0 m	kg			*24 850	*24 850	*22 350	*22 350	*19 350	19 300	*16 400	14 800	*13 300	12 050					*12 350	11 500	10.90
-7.5 m	kg					*17 100	*17 100	*14 900	*14 900	*12 100	*12 100							*10 950	*10 950	9.47

\*Indicates that the load is limited by hydraulic lifting capacity rather than tipping load. The above loads are in compliance with hydraulic excavator lift capacity standard ISO 10567:2007. They do not exceed 87% of hydraulic lifting capacity or 75% of tipping load. Weight of all lifting accessories must be deducted from the above lifting capacities. Lifting capacities are based on the machine standing on a firm, uniform supporting surface.

Always refer to the appropriate Operation and Maintenance Manual for specific product information.

# 390D L Hydraulic Excavator Specifications

## 390D L Reach Boom Lift Capacities – EAME



Load Point Height



Load at Maximum Reach



Load Radius Over Front



Load Radius Over Side

Boom – 10.0 m

Coupler – N/A

Bucket – None

Stick – R4.4 m

Shoes – 650 mm double grouser

Load Point Height	kg	3.0 m		4.5 m		6.0 m		7.5 m		9.0 m		10.5 m		12.0 m		13.5 m		m		
		Front	Side	Front	Side	Front	Side	Front	Side	Front	Side	Front	Side	Front	Side	Front	Side	Front	Side	
12.0 m	kg											*12 950	*12 950					*12 950	*12 950	10.50
10.5 m	kg											*14 550	*14 550					*12 450	12 400	11.67
9.0 m	kg											*14 850	*14 850	*13 950	11 700			*12 250	10 700	12.55
7.5 m	kg									*17 250	*17 250	*15 450	14 450	*14 150	11 450			*12 250	9550	13.20
6.0 m	kg					*28 250	*28 250	*22 100	*22 100	*18 500	17 600	*16 200	13 850	*14 600	11 100	*13 450	9000	*12 450	8800	13.66
4.5 m	kg							*24 250	21 450	*19 850	16 600	*17 000	13 200	*15 050	10 700	13 350	8750	12 650	8300	13.93
3.0 m	kg							*25 900	20 050	*20 950	15 650	*17 750	12 600	*15 500	10 300	13 100	8550	12 300	8000	14.04
1.5 m	kg							*26 700	19 100	*21 650	14 950	*18 250	12 100	15 350	9950	12 900	8300	12 200	7850	13.98
Ground Line	kg					*13 200	*13 200	*26 650	18 600	*21 850	14 500	18 300	11 700	15 100	9700	12 750	8150	12 400	7950	13.76
-1.5 m	kg					*20 100	*20 100	*25 850	18 450	*21 500	14 250	18 050	11 500	14 950	9550			12 850	8250	13.36
-3.0 m	kg			*17 950	*17 950	*28 350	26 100	*24 450	18 450	*20 600	14 200	*17 400	11 450	*14 700	9550			*13 200	8800	12.78
-4.5 m	kg			*26 800	*26 800	*26 100	*26 100	*22 350	18 650	*18 950	14 300	*15 950	11 550					*12 950	9750	11.98
-6.0 m	kg			*24 850	*24 850	*22 350	*22 350	*19 350	19 100	*16 400	14 650	*13 300	11 900					*12 350	11 350	10.90
-7.5 m	kg					*17 100	*17 100	*14 900	*14 900	*12 100	*12 100							*10 950	*10 950	9.47

\*Indicates that the load is limited by hydraulic lifting capacity rather than tipping load. The above loads are in compliance with hydraulic excavator lift capacity standard ISO 10567:2007. They do not exceed 87% of hydraulic lifting capacity or 75% of tipping load. Weight of all lifting accessories must be deducted from the above lifting capacities. Lifting capacities are based on the machine standing on a firm, uniform supporting surface.

Always refer to the appropriate Operation and Maintenance Manual for specific product information.

## 390D L General Boom Lift Capacities – EAME



Load Point Height



Load at Maximum Reach



Load Radius Over Front



Load Radius Over Side

**Boom** – 8.4 m

**Coupler** – N/A

**Bucket** – None

**Stick** – R5.5 m

**Shoes** – 750 mm double grouser

Load Point Height	3.0 m		4.5 m		6.0 m		7.5 m		9.0 m		10.5 m		12.0 m		13.5 m		m		
	Front	Side	Front	Side	Front	Side	Front	Side	Front	Side	Front	Side	Front	Side	Front	Side	Front	Side	
12.0 m	kg																*9050	*9050	9.83
10.5 m	kg									*10 950	*10 950						*8500	*8500	11.07
9.0 m	kg									*13 000	*13 000						*8200	*8200	12.00
7.5 m	kg									*14 450	*14 450	*11 500	*11 500				*8050	*8050	12.68
6.0 m	kg							*17 550	*17 550	*16 200	15 250	*13 500	12 200				*8100	*8100	13.15
4.5 m	kg				*27 100	*27 100	*22 200	*22 200	*19 200	18 800	*17 150	14 750	*15 400	11 900			*8250	*8250	13.43
3.0 m	kg				*31 500	*31 500	*24 800	23 600	*20 800	18 000	*18 200	14 250	*16 300	11 550	*9000	*9000	*8600	*8600	13.54
1.5 m	kg				*34 800	30 950	*26 950	22 400	*22 200	17 200	*19 050	13 750	16 700	11 200			*9050	*9050	13.48
Ground Line	kg			*19 000	*19 000	*36 450	29 700	*28 300	21 500	*23 150	16 600	*19 650	13 300	16 400	10 950		*9750	9450	13.25
-1.5 m	kg	*14 250	*14 250	*23 200	*23 200	*36 600	29 050	*28 750	20 950	*23 500	16 200	19 700	13 000	16 250	10 800		*10 700	9800	12.84
-3.0 m	kg	*20 200	*20 200	*29 400	*29 400	*35 350	28 800	*28 150	20 650	*23 050	15 950	*19 250	12 900	*15 550	10 750		*12 200	10 500	12.23
-4.5 m	kg	*27 050	*27 050	*37 750	*37 750	*32 850	28 900	*26 400	20 650	*21 650	15 950	*17 700	12 900				*14 500	11 650	11.39
-6.0 m	kg	*35 550	*35 550	*35 950	*35 950	*28 700	*28 700	*23 250	20 900	*18 750	16 200						*14 900	13 650	10.26
-7.5 m	kg			*27 300	*27 300	*22 250	*22 250	*17 700	*17 700								*13 650	*13 650	8.71

\*Indicates that the load is limited by hydraulic lifting capacity rather than tipping load. The above loads are in compliance with hydraulic excavator lift capacity standard ISO 10567:2007. They do not exceed 87% of hydraulic lifting capacity or 75% of tipping load. Weight of all lifting accessories must be deducted from the above lifting capacities. Lifting capacities are based on the machine standing on a firm, uniform supporting surface.

Always refer to the appropriate Operation and Maintenance Manual for specific product information.

# 390D L Hydraulic Excavator Specifications

## 390D L General Boom Lift Capacities – EAME



Load Point Height



Load at Maximum Reach



Load Radius Over Front



Load Radius Over Side

**Boom** – 8.4 m

**Coupler** – N/A

**Bucket** – None

**Stick** – R5.5 m

**Shoes** – 650 mm double grouser

Load Point Height	3.0 m		4.5 m		6.0 m		7.5 m		9.0 m		10.5 m		12.0 m		13.5 m		Load at Maximum Reach		m	
	Load Radius Over Front	Load Radius Over Side	Load Radius Over Front	Load Radius Over Side	Load Radius Over Front	Load Radius Over Side	Load Radius Over Front	Load Radius Over Side	Load Radius Over Front	Load Radius Over Side	Load Radius Over Front	Load Radius Over Side	Load Radius Over Front	Load Radius Over Side	Load Radius Over Front	Load Radius Over Side	Load Radius Over Front	Load Radius Over Side		
12.0 m	kg																	*9050	*9050	9.83
10.5 m	kg									*10 950	*10 950							*8500	*8500	11.07
9.0 m	kg									*13 000	*13 000							*8200	*8200	12.00
7.5 m	kg									*14 450	*14 450	*11 500	*11 500					*8050	*8050	12.68
6.0 m	kg								*17 550	*17 550	*16 200	15 150	*13 500	12 050				*8100	*8100	13.15
4.5 m	kg				*27 100	*27 100	*22 200	*22 200	*19 200	18 650	*17 150	14 650	*15 400	11 750				*8250	*8250	13.43
3.0 m	kg				*31 500	*31 500	*24 800	23 350	*20 800	17 800	*18 200	14 100	*16 300	11 400	*9000	*9000		*8600	*8600	13.54
1.5 m	kg				*34 800	30 650	*26 950	22 150	*22 200	17 050	*19 050	13 600	16 500	11 100				*9050	*9050	13.48
Ground Line	kg			*19 000	*19 000	*36 450	29 400	*28 300	21 300	*23 150	16 450	*19 650	13 150	16 250	10 850			*9750	9350	13.25
-1.5 m	kg	*14 250	*14 250	*23 200	*23 200	*36 600	28 750	*28 750	20 700	*23 500	16 000	19 500	12 900	16 050	10 650			*10 700	9700	12.84
-3.0 m	kg	*20 200	*20 200	*29 400	*29 400	*35 350	28 500	*28 150	20 450	*23 050	15 800	*19 250	12 750	*15 550	10 600			*12 200	10 350	12.23
-4.5 m	kg	*27 050	*27 050	*37 750	*37 750	*32 850	28 600	*26 400	20 450	*21 650	15 750	*17 700	12 750					*14 500	11 500	11.39
-6.0 m	kg	*35 550	*35 550	*35 950	*35 950	*28 700	*28 700	*23 250	20 700	*18 750	16 000							*14 900	13 500	10.26
-7.5 m	kg			*27 300	*27 300	*22 250	*22 250	*17 700	*17 700									*13 650	*13 650	8.71

\*Indicates that the load is limited by hydraulic lifting capacity rather than tipping load. The above loads are in compliance with hydraulic excavator lift capacity standard ISO 10567:2007. They do not exceed 87% of hydraulic lifting capacity or 75% of tipping load. Weight of all lifting accessories must be deducted from the above lifting capacities. Lifting capacities are based on the machine standing on a firm, uniform supporting surface.

Always refer to the appropriate Operation and Maintenance Manual for specific product information.

## 390D L General Boom Lift Capacities – EAME



Load Point Height



Load at Maximum Reach



Load Radius Over Front



Load Radius Over Side



















**Boom – 8.4 m**

**Coupler – N/A**

**Bucket – None**

**Stick – R4.4 m**

**Shoes – 750 mm double grouser**

	3.0 m		4.5 m		6.0 m		7.5 m		9.0 m		10.5 m		12.0 m				m	
																		
10.5 m	kg								*15 350	*15 350					*11 350	*11 350	9.79	
9.0 m	kg								*17 350	*17 350	*13 350	*13 350			*10 900	*10 900	10.82	
7.5 m	kg								*18 050	*18 050	*16 900	15 150			*10 700	*10 700	11.57	
6.0 m	kg							*21 900	*21 900	*19 250	18 950	*17 500	14 800	*11 750	*11 750	*10 750	*10 750	12.09
4.5 m	kg					*30 450	*30 450	*24 300	23 950	*20 650	18 200	*18 250	14 350	*15 150	11 550	*11 050	10 900	12.40
3.0 m	kg					*34 200	31 400	*26 500	22 750	*22 000	17 450	*19 050	13 900	16 750	11 300	*11 500	10 550	12.52
1.5 m	kg					*36 300	29 900	*28 100	21 750	*23 050	16 800	*19 650	13 450	16 500	11 050	*12 200	10 450	12.46
Ground Line	kg					*36 650	29 100	*28 750	21 050	*23 500	16 300	19 800	13 150	16 300	10 850	*13 300	10 600	12.21
-1.5 m	kg			*24 000	*24 000	*35 650	28 850	*28 400	20 750	*23 300	16 050	*19 500	12 950			*14 850	11 100	11.76
-3.0 m	kg	*23 450	*23 450	*33 350	*33 350	*33 350	28 900	*27 000	20 650	*22 200	15 950	*18 150	12 950			*16 500	12 100	11.09
-4.5 m	kg	*33 050	*33 050	*36 400	*36 400	*29 700	29 200	*24 300	20 850	*19 700	16 150					*16 150	13 800	10.15
-6.0 m	kg			*28 900	*28 900	*24 100	*24 100	*19 550	*19 550							*15 050	*15 050	8.85



















**Boom – 8.4 m**

**Coupler – N/A**

**Bucket – None**

**Stick – R4.4 m**

**Shoes – 650 mm double grouser**

	3.0 m		4.5 m		6.0 m		7.5 m		9.0 m		10.5 m		12.0 m				m	
																		
10.5 m	kg								*15 350	*15 350					*11 350	*11 350	9.79	
9.0 m	kg								*17 350	*17 350	*13 350	*13 350			*10 900	*10 900	10.82	
7.5 m	kg								*18 050	*18 050	*16 900	15 000			*10 700	*10 700	11.57	
6.0 m	kg							*21 900	*21 900	*19 250	18 800	*17 500	14 650	*11 750	11 650	*10 750	*10 750	12.09
4.5 m	kg					*30 450	*30 450	*24 300	23 750	*20 650	18 050	*18 250	14 200	*15 150	11 400	*11 050	10 800	12.40
3.0 m	kg					*34 200	31 100	*26 500	22 500	*22 000	17 250	*19 050	13 750	16 600	11 150	*11 500	10 400	12.52
1.5 m	kg					*36 300	29 600	*28 100	21 500	*23 050	16 600	*19 650	13 300	16 300	10 900	*12 200	10 300	12.46
Ground Line	kg					*36 650	28 800	*28 750	20 850	*23 500	16 150	19 600	13 000	16 150	10 750	*13 300	10 500	12.21
-1.5 m	kg			*24 000	*24 000	*35 650	28 500	*28 400	20 500	*23 300	15 850	19 400	12 800			*14 850	11 000	11.76
-3.0 m	kg	*23 450	*23 450	*33 350	*33 350	*33 350	28 550	*27 000	20 450	*22 200	15 800	*18 150	12 800			*16 500	11 950	11.09
-4.5 m	kg	*33 050	*33 050	*36 400	*36 400	*29 700	28 900	*24 300	20 650	*19 700	15 950					*16 150	13 650	10.15
-6.0 m	kg			*28 900	*28 900	*24 100	*24 100	*19 550	*19 550							*15 050	*15 050	8.85

\*Indicates that the load is limited by hydraulic lifting capacity rather than tipping load. The above loads are in compliance with hydraulic excavator lift capacity standard ISO 10567:2007. They do not exceed 87% of hydraulic lifting capacity or 75% of tipping load. Weight of all lifting accessories must be deducted from the above lifting capacities. Lifting capacities are based on the machine standing on a firm, uniform supporting surface.

Always refer to the appropriate Operation and Maintenance Manual for specific product information.

# 390D L Hydraulic Excavator Specifications

## 390D L General Boom Lift Capacities – EAME



Load Point Height



Load at Maximum Reach



Load Radius Over Front



Load Radius Over Side

Boom – 8.4 m

Coupler – N/A

Bucket – None

Stick – GP3.4 m

Shoes – 750 mm double grouser

Load Point Height	kg	3.0 m		4.5 m		6.0 m		7.5 m		9.0 m		10.5 m		Load at Maximum Reach		m	
		Front	Side	Front	Side	Front	Side	Front	Side	Front	Side	Front	Side	Front	Side		
10.5 m	kg														*15 550	*15 550	8.73
9.0 m	kg									*19 000	*19 000				*14 600	*14 600	9.88
7.5 m	kg							*21 700	*21 700	*19 500	18 900	*17 150	14 550	*14 200	14 050		10.70
6.0 m	kg					*29 050	*29 050	*23 650	*23 650	*20 500	18 350	*18 500	14 300	*14 150	12 700		11.25
4.5 m	kg					*33 200	32 000	*25 850	23 100	*21 700	17 650	*19 050	13 950	*14 350	11 850		11.59
3.0 m	kg							*27 650	22 050	*22 800	17 000	*19 600	13 550	*14 900	11 450		11.72
1.5 m	kg							*28 650	21 250	*23 450	16 450	*19 900	13 200	*15 800	11 400		11.65
Ground Line	kg					*33 250	28 900	*28 650	20 800	*23 500	16 100	19 650	13 000	*17 150	11 650		11.38
-1.5 m	kg			*21 450	*21 450	*33 850	28 900	*27 600	20 650	*22 700	16 000	*18 600	12 950	*17 400	12 350		10.90
-3.0 m	kg			*36 000	*36 000	*30 650	29 150	*25 350	20 750	*20 700	16 050			*16 900	13 700		10.17
-4.5 m	kg			*30 050	*30 050	*25 950	*25 950	*21 450	21 150	*16 400	*16 400			*15 800	*15 800		9.13
-6.0 m	kg					*18 500	*18 500	*13 950	*13 950					*13 300	*13 300		7.63

Boom – 8.4 m

Coupler – N/A

Bucket – None

Stick – GP3.4 m

Shoes – 650 mm double grouser

Load Point Height	kg	3.0 m		4.5 m		6.0 m		7.5 m		9.0 m		10.5 m		Load at Maximum Reach		m	
		Front	Side	Front	Side	Front	Side	Front	Side	Front	Side	Front	Side	Front	Side		
10.5 m	kg														*15 550	*15 550	8.73
9.0 m	kg									*19 000	*19 000				*14 600	*14 600	9.88
7.5 m	kg							*21 700	*21 700	*19 500	18 750	*17 150	14 400	*14 200	13 900		10.70
6.0 m	kg					*29 050	*29 050	*23 650	*23 650	*20 500	18 150	*18 500	14 150	*14 150	12 550		11.25
4.5 m	kg					*33 200	31 700	*25 850	22 900	*21 700	17 450	*19 050	13 800	*14 350	11 750		11.59
3.0 m	kg							*27 650	21 800	*22 800	16 800	*19 600	13 400	*14 900	11 300		11.72
1.5 m	kg							*28 650	21 050	*23 450	16 300	19 700	13 050	*15 800	11 250		11.65
Ground Line	kg					*33 250	28 600	*28 650	20 600	*23 500	15 950	19 450	12 850	*17 150	11 500		11.38
-1.5 m	kg			*21 450	*21 450	*33 850	28 600	*27 600	20 450	*22 700	15 800	*18 600	12 800	*17 400	12 250		10.90
-3.0 m	kg			*36 000	*36 000	*30 650	28 850	*25 350	20 550	*20 700	15 900			*16 900	13 550		10.17
-4.5 m	kg			*30 050	*30 050	*25 950	*25 950	*21 450	20 950	*16 400	16 350			*15 800	*15 800		9.13
-6.0 m	kg					*18 500	*18 500	*13 950	*13 950					*13 300	*13 300		7.63

\*Indicates that the load is limited by hydraulic lifting capacity rather than tipping load. The above loads are in compliance with hydraulic excavator lift capacity standard ISO 10567:2007. They do not exceed 87% of hydraulic lifting capacity or 75% of tipping load. Weight of all lifting accessories must be deducted from the above lifting capacities. Lifting capacities are based on the machine standing on a firm, uniform supporting surface.

Always refer to the appropriate Operation and Maintenance Manual for specific product information.

## 390D L General Boom Lift Capacities – EAME



Load Point Height



Load at Maximum Reach



Load Radius Over Front



Load Radius Over Side

















**Boom** – 8.4 m

**Coupler** – N/A

**Bucket** – None

**Stick** – GP2.92 m

**Shoes** – 750 mm double grouser

			3.0 m		4.5 m		6.0 m		7.5 m		9.0 m		10.5 m				m	
																		
10.5 m	kg								*21 400	*21 400					*17 650	*17 650	8.15	
9.0 m	kg								*21 450	*21 450	*20 050	19 000			*16 450	*16 450	9.38	
7.5 m	kg								*22 700	*22 700	*20 300	18 750			*15 900	15 000	10.23	
6.0 m	kg							*30 550	*30 550	*24 600	24 050	*21 200	18 200	*19 150	14 200	*15 800	13 500	10.81
4.5 m	kg								*26 650	22 900	*22 300	17 550	*19 550	13 900	*16 050	12 600	11.16	
3.0 m	kg								*28 250	21 900	*23 200	16 950	*19 950	13 550	*16 650	12 150	11.29	
1.5 m	kg								*28 950	21 200	*23 700	16 450	19 950	13 250	*17 650	12 050	11.22	
Ground Line	kg					*30 450	29 050	*28 550	20 900	*23 500	16 200	*19 550	13 100	*18 300	12 400	10.95		
-1.5 m	kg					*32 700	29 150	*27 150	20 800	*22 350	16 100			*18 000	13 250	10.44		
-3.0 m	kg			*32 750	*32 750	*29 200	*29 200	*24 450	21 000	*19 850	16 300			*17 300	14 900	9.68		
-4.5 m	kg			*26 750	*26 750	*23 950	*23 950	*19 850	*19 850					*15 750	*15 750	8.58		

















**Boom** – 8.4 m

**Coupler** – N/A

**Bucket** – None

**Stick** – GP2.92 m

**Shoes** – 650 mm double grouser

			3.0 m		4.5 m		6.0 m		7.5 m		9.0 m		10.5 m				m	
																		
10.5 m	kg								*21 400	*21 400					*17 650	*17 650	8.15	
9.0 m	kg								*21 450	*21 450	*20 050	18 850			*16 450	*16 450	9.38	
7.5 m	kg								*22 700	*22 700	*20 300	18 550			*15 900	14 900	10.23	
6.0 m	kg							*30 550	*30 550	*24 600	23 850	*21 200	18 000	*19 150	14 050	*15 800	13 350	10.81
4.5 m	kg								*26 650	22 650	*22 300	17 350	*19 550	13 750	*16 050	12 450	11.16	
3.0 m	kg								*28 250	21 650	*23 200	16 750	*19 950	13 400	*16 650	12 000	11.29	
1.5 m	kg								*28 950	21 000	*23 700	16 300	19 700	13 100	*17 650	11 950	11.22	
Ground Line	kg					*30 450	28 750	*28 550	20 650	*23 500	16 000	*19 550	12 950	*18 300	12 300	10.95		
-1.5 m	kg					*32 700	28 850	*27 150	20 600	*22 350	15 950			*18 000	13 100	10.44		
-3.0 m	kg			*32 750	*32 750	*29 200	29 200	*24 450	20 800	*19 850	16 100			*17 300	14 700	9.68		
-4.5 m	kg			*26 750	*26 750	*23 950	*23 950	*19 850	*19 850					*15 750	*15 750	8.58		

\*Indicates that the load is limited by hydraulic lifting capacity rather than tipping load. The above loads are in compliance with hydraulic excavator lift capacity standard ISO 10567:2007. They do not exceed 87% of hydraulic lifting capacity or 75% of tipping load. Weight of all lifting accessories must be deducted from the above lifting capacities. Lifting capacities are based on the machine standing on a firm, uniform supporting surface.

Always refer to the appropriate Operation and Maintenance Manual for specific product information.

# 390D L Hydraulic Excavator Specifications

## 390D L Mass Boom Lift Capacities – EAME



Load Point Height



Load at Maximum Reach



Load Radius Over Front



Load Radius Over Side

**Boom** – 7.25 m  
**Stick** – M3.4 m

**Coupler** – N/A  
**Shoes** – 750 mm double grouser

**Bucket** – None

Load Point Height	kg	3.0 m		4.5 m		6.0 m		7.5 m		9.0 m		Load Radius Over Side		m
		Front	Side	Front	Side	Front	Side	Front	Side	Front	Side	Front	Side	
10.5 m	kg											*17 400	*17 400	6.96
9.0 m	kg							*21 650	*21 650			*15 900	*15 900	8.36
7.5 m	kg							*23 500	*23 500	*18 950	*18 950	*15 350	*15 350	9.32
6.0 m	kg					*29 350	*29 350	*24 900	*24 900	*22 200	18 650	*15 250	*15 250	9.95
4.5 m	kg			*45 600	*45 600	*33 050	*33 050	*26 800	24 050	*23 000	18 150	*15 600	14 500	10.33
3.0 m	kg					*36 200	32 100	*28 500	23 050	*23 850	17 550	*16 350	13 950	10.47
1.5 m	kg					*37 700	30 800	*29 500	22 200	*24 250	17 100	*17 600	13 850	10.40
Ground Line	kg			*27 950	*27 950	*37 150	30 100	*29 300	21 700	*23 800	16 750	*19 550	14 300	10.10
-1.5 m	kg	*23 550	*23 550	*41 700	*41 700	*34 700	29 950	*27 650	21 500	*22 000	16 650	*19 800	15 400	9.55
-3.0 m	kg	*38 700	*38 700	*37 000	*37 000	*30 150	*30 150	*24 000	21 650			*18 800	17 700	8.70
-4.5 m	kg			*27 250	*27 250	*22 550	*22 550					*16 350	*16 350	7.46

**Boom** – 7.25 m  
**Stick** – M3.4 m

**Coupler** – N/A  
**Shoes** – 650 mm double grouser

**Bucket** – None

Load Point Height	kg	3.0 m		4.5 m		6.0 m		7.5 m		9.0 m		Load Radius Over Side		m
		Front	Side	Front	Side	Front	Side	Front	Side	Front	Side	Front	Side	
10.5 m	kg											*17 400	*17 400	6.96
9.0 m	kg							*21 650	*21 650			*15 900	*15 900	8.36
7.5 m	kg							*23 500	*23 500	*18 950	18 850	*15 350	*15 350	9.32
6.0 m	kg					*29 350	*29 350	*24 900	24 850	*22 200	18 500	*15 250	*15 250	9.95
4.5 m	kg			*45 600	*45 600	*33 050	*33 050	*26 800	23 850	*23 000	17 950	*15 600	14 400	10.33
3.0 m	kg					*36 200	31 800	*28 500	22 800	*23 850	17 400	*16 350	13 800	10.47
1.5 m	kg					*37 700	30 500	*29 500	22 000	*24 250	16 900	*17 600	13 700	10.40
Ground Line	kg			*27 950	*27 950	*37 150	29 800	*29 300	21 450	*23 800	16 600	*19 550	14 150	10.10
-1.5 m	kg	*23 550	*23 550	*41 700	*41 700	*34 700	29 650	*27 650	21 300	*22 000	16 500	*19 800	15 250	9.55
-3.0 m	kg	*38 700	*38 700	*37 000	*37 000	*30 150	29 850	*24 000	21 450			*18 800	17 500	8.70
-4.5 m	kg			*27 250	*27 250	*22 550	*22 550					*16 350	*16 350	7.46

\*Indicates that the load is limited by hydraulic lifting capacity rather than tipping load. The above loads are in compliance with hydraulic excavator lift capacity standard ISO 10567:2007. They do not exceed 87% of hydraulic lifting capacity or 75% of tipping load. Weight of all lifting accessories must be deducted from the above lifting capacities. Lifting capacities are based on the machine standing on a firm, uniform supporting surface.

Always refer to the appropriate Operation and Maintenance Manual for specific product information.

## 390D L Mass Boom Lift Capacities – EAME



Load Point Height



Load at Maximum Reach



Load Radius Over Front



Load Radius Over Side

**Boom – 7.25 m**

**Coupler – N/A**

**Bucket – None**

**Stick – M2.92 m**

**Shoes – 750 mm double grouser**

 Load Point Height kg	3.0 m		4.5 m		6.0 m		7.5 m		9.0 m		 Load at Maximum Reach kg		m	
	 Load Radius Over Front kg	 Load Radius Over Side kg	 Load Radius Over Front kg	 Load Radius Over Side kg	 Load Radius Over Front kg	 Load Radius Over Side kg	 Load Radius Over Front kg	 Load Radius Over Side kg	 Load Radius Over Front kg	 Load Radius Over Side kg	 Load Radius Over Front kg	 Load Radius Over Side kg		
10.5 m												*20 950	*20 950	6.27
9.0 m							*22 600	*22 600				*18 950	*18 950	7.81
7.5 m							*24 400	*24 400				*18 200	*18 200	8.82
6.0 m			*39 800	*39 800	*30 550	*30 550	*25 700	24 650	*22 750	18 350		*18 100	16 700	9.49
4.5 m					*34 100	33 250	*27 400	23 650	*23 400	17 850		*18 550	15 350	9.89
3.0 m					*36 800	31 450	*28 850	22 650	*24 000	17 300		*19 500	14 700	10.04
1.5 m					*37 550	30 350	*29 450	21 900	*24 150	16 900		*21 150	14 600	9.96
Ground Line			*25 950	*25 950	*36 300	29 850	*28 850	21 500	*23 300	16 650		*20 950	15 150	9.64
-1.5 m			*40 350	*40 350	*33 250	29 850	*26 650	21 400	*20 650	16 700		*20 300	16 550	9.07
-3.0 m			*33 300	*33 300	*27 950	*27 950	*22 050	21 700				*18 850	*18 850	8.17
-4.5 m					*18 900	*18 900						*15 600	*15 600	6.77

**Boom – 7.25 m**

**Coupler – N/A**

**Bucket – None**

**Stick – M2.92 m**

**Shoes – 650 mm double grouser**

 Load Point Height kg	3.0 m		4.5 m		6.0 m		7.5 m		9.0 m		 Load at Maximum Reach kg		m	
	 Load Radius Over Front kg	 Load Radius Over Side kg	 Load Radius Over Front kg	 Load Radius Over Side kg	 Load Radius Over Front kg	 Load Radius Over Side kg	 Load Radius Over Front kg	 Load Radius Over Side kg	 Load Radius Over Front kg	 Load Radius Over Side kg	 Load Radius Over Front kg	 Load Radius Over Side kg		
10.5 m												*20 950	*20 950	6.27
9.0 m							*22 600	*22 600				*18 950	*18 950	7.81
7.5 m							*24 400	*24 400				*18 200	*18 200	8.82
6.0 m			*39 800	*39 800	*30 550	*30 550	*25 700	24 450	*22 750	18 150		*18 100	16 550	9.49
4.5 m					*34 100	32 950	*27 400	23 400	*23 400	17 650		*18 550	15 200	9.89
3.0 m					*36 800	31 150	*28 850	22 450	*24 000	17 150		*19 500	14 500	10.04
1.5 m					*37 550	30 050	*29 450	21 700	*24 150	16 700		*21 150	14 450	9.96
Ground Line			*25 950	*25 950	*36 300	29 550	*28 850	21 300	*23 300	16 450		*20 950	15 000	9.64
-1.5 m			*40 350	*40 350	*33 250	29 550	*26 650	21 200	*20 650	16 500		*20 300	16 350	9.07
-3.0 m			*33 300	*33 300	*27 950	*27 950	*22 050	21 500				*18 850	*18 850	8.17
-4.5 m					*18 900	*18 900						*15 600	*15 600	6.77

\*Indicates that the load is limited by hydraulic lifting capacity rather than tipping load. The above loads are in compliance with hydraulic excavator lift capacity standard ISO 10567:2007. They do not exceed 87% of hydraulic lifting capacity or 75% of tipping load. Weight of all lifting accessories must be deducted from the above lifting capacities. Lifting capacities are based on the machine standing on a firm, uniform supporting surface.

Always refer to the appropriate Operation and Maintenance Manual for specific product information.

# 390D L Standard Equipment

Standard equipment may vary. Consult your Cat dealer for details.

## ELECTRICAL

Alternator – 75 amp  
Lights: Cab interior  
Signal/warning horn  
Power supply at battery compartment – 24V

## ENGINE/POWER TRAIN

Automatic engine speed control  
Automatic swing parking brake  
Automatic travel parking brakes  
Cat® C18 engine with ACERT™ Technology  
Altitude capability to 2300 m  
without derating  
High ambient cooling, 52° C capability  
Side-by-side cooling system  
with separately mounted AC condenser  
and variable speed fan  
Two speed travel  
Water separator  
with level indicator for fuel line  
Electric fuel priming pump

## GUARDS

Heavy-duty travel motor guards  
on upper frame  
Heavy-duty swivel guard on undercarriage  
Heavy-duty travel motor guards  
on undercarriage

## OPERATOR STATION

Air conditioner, heater and defroster  
with automatic climate control  
Ashtray and 24V lighter  
Beverage/cup holder  
Coat hook  
Console-mounted, electronic-type joysticks  
with adjustable gain and response  
Floor mat  
Instrument panel and gauges  
with full color graphical display  
Literature compartment  
Neutral lever (lock-out) for all controls  
Positive filtered ventilation  
Pressurized cab  
Retractable seat belt, 75 mm wide  
Stationary skylight (polycarbonate)  
Sunshade for windshield and skylight  
Travel control pedals  
with removable hand levers  
Windshield wipers and washers  
(upper and lower)

## UNDERCARRIAGE

Grease lubricated and positive pin  
retention track  
Hydraulic track adjusters  
Long, variable gauge  
Steps, four

## OTHER STANDARD EQUIPMENT

Auxiliary hydraulic valve  
for hydro-mechanical tools  
Cat® one key security system  
with locks for doors, cab and fuel cap  
Catwalks, left and right sides  
Crossroller-type swing bearing  
Drive for auxiliary pump  
Hand control pattern changer  
Mirrors, left and right  
S·O·S<sup>SM</sup> quick sampling valves  
for engine oil and hydraulic oil  
Steel firewall between engine  
and hydraulic pumps  
Wiring provisions for Cat® Product Link,  
AutoLube System and lighted beacon

Optional equipment may vary. Consult your Cat dealer for details.

## FRONT LINKAGE

Bucket linkages

VB family for VB sticks

(available with or without lifting eye)

WB family for WB sticks

(available with or without lifting eye)

Buckets – see charts

Booms (with two working lights)

Mass Excavation – 7250 mm

Reach – 10 000 mm

GP – 8400 mm

Sticks

For Mass Boom

- M2.92JC
- M3.4JC

For Reach Boom

- R5.5HB2
- R4.4HB2

For GP Boom

- R5.5HB2
- R4.4HB2
- GP3.4JC
- GP2.92JC

Tips, sidecutters and edge protectors

## TRACK

Double grouser, heavy duty

- 650 mm
- 750 mm
- 900 mm

## GUARDS

FOGS (Falling Object Guard System)

including overhead and windshield guards

Track guiding guards

- Full length
- Center section

Wire mesh screen for windshield

Auxiliary controls and lines

Auxiliary boom lines

(high pressure for reach and mass booms)

Auxiliary stick lines

(high pressure for reach and mass booms)

Basic control arrangements:

- Single action – one way, high-pressure circuit for hammer application
- Combined function – one way, high-pressure circuit for hammer application function for one-way or two-way high pressure

## MISCELLANEOUS OPTIONS

Boom lowering control device with SmartBoom™

Cab front rain protector

Converters, 7 amp-12V (two)

Electric refueling pump

Fine filtration filter

Jump start terminals

Reversible cooling fan

including protective screen

Starting aid with ether for cold weather

Stick lowering control device

Travel alarm with cut-off switch

## OPERATOR COMPARTMENT

Joysticks

Four button joystick

for standard machine or single action auxiliary control

Thumb wheel modulation joystick

for use with combined auxiliary control

Lunch box storage with lid

Machine Security System

with programmable keys

Radio

AM/FM radio-mounted in right console with antenna and two speakers

Radio-ready mounting at rear location including 24V to 12V converter, speakers, antenna

Seat

Adjustable, high back

with mechanical suspension

Adjustable, high back

with air suspension

Adjustable, high back heated

with air suspension

Straight travel pedal

Windshield

One-piece, standard duty

70-30 split, sliding





# 390D L Hydraulic Excavator

For more complete information on Cat products, dealer services, and industry solutions, visit us on the web at [www.cat.com](http://www.cat.com)

© 2010 Caterpillar Inc.  
All rights reserved

HEHH4383-01 (09-2010)

Materials and specifications are subject to change without notice. Featured machines in photos may include additional equipment. See your Cat dealer for available options.

CAT, CATERPILLAR, SAFETY.CAT.COM, their respective logos, "Caterpillar Yellow" and the "Power Edge" trade dress, as well as corporate and product identity used herein, are trademarks of Caterpillar and may not be used without permission.

